

# Octanorm Information Sheet

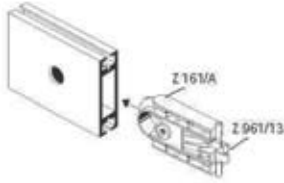

• Beam Detail



• Post Detail

## IMPORTANT NOTICE TO EXHIBITORS

We take pride in providing display equipment for our exhibitors. Your stand and panels are on hire and we request that pins, staples, screws, nails, bolts, paint, and most double sided tape, etc.

## ARE NOT TO BE USED

The only acceptable fixing methods are approved velcro, bluetak, shelving, hooks, and hanging apparatus which are available from the ExpoNet service site desk.

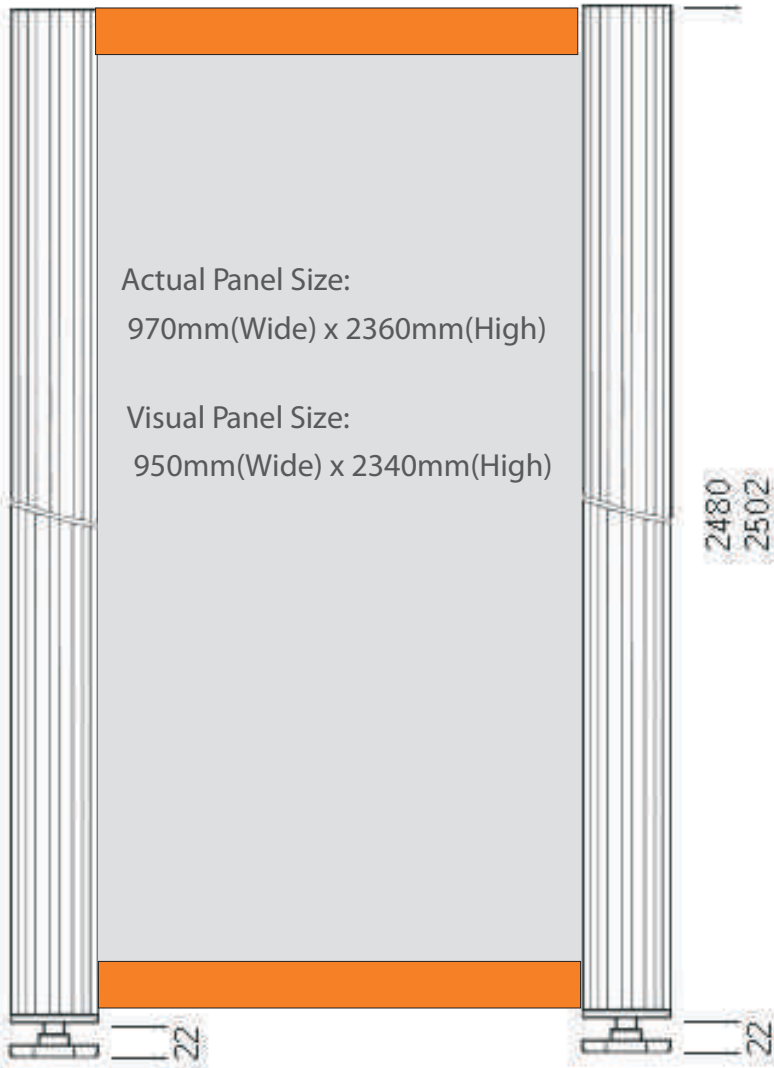

• Post Detail With Panel Insert

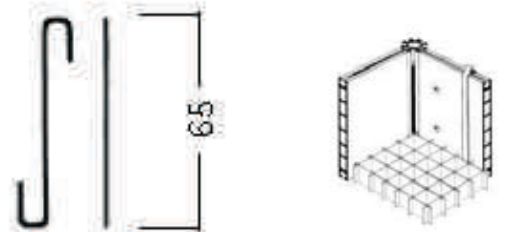

• Optional S-Hook  
With Hanging Detail Off Top Beam

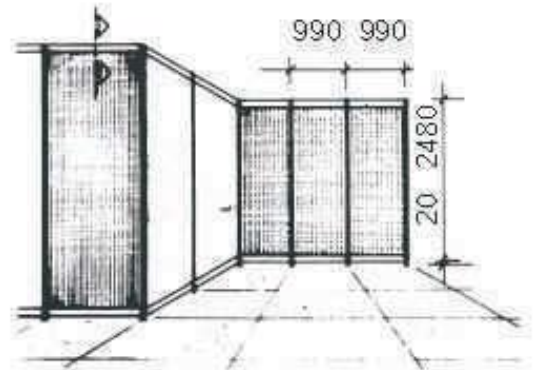

• Overall Booth Drawing (3m x 3m)

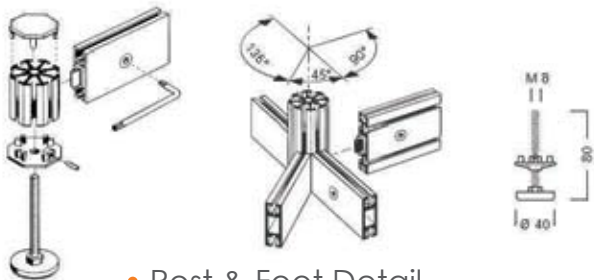

• Post & Foot Detail

